



GE Pro-HT
GE Pro-M2

User Manual

Version 3.0
Published July 2003
Copyright©2003 ASRock INC. All rights reserved.

Copyright Notice:

No part of this manual may be reproduced, transcribed, transmitted, or translated in any language, in any form or by any means, except duplication of documentation by the purchaser for backup purpose, without written consent of ASRock Inc.

Products and corporate names appearing in this manual may or may not be registered trademarks or copyrights of their respective companies, and are used only for identification or explanation and to the owners' benefit, without intent to infringe.

Disclaimer:

Specifications and information contained in this manual are furnished for informational use only and subject to change without notice, and should not be constructed as a commitment by ASRock. ASRock assumes no responsibility for any errors or omissions that may appear in this manual.

With respect to the contents of this manual, ASRock does not provide warranty of any kind, either expressed or implied, including but not limited to the implied warranties or conditions of merchantability or fitness for a particular purpose.

In no event shall ASRock, its directors, officers, employees, or agents be liable for any indirect, special, incidental, or consequential damages (including damages for loss of profits, loss of business, loss of data, interruption of business and the like), even if ASRock has been advised of the possibility of such damages arising from any defect or error in the manual or product.

ASRock Website: <http://www.asrock.com>

Contents

1	Introduction	4
1.1	Package Contents	4
1.2	Specifications	5
1.3	Motherboard Layout (GE Pro-HT)	7
1.4	Motherboard Layout (GE Pro-M2)	8
1.5	ASRock I/O™ (GE Pro-HT / GE Pro-M2)	9
2	Installation	10
2.1	Screw Holes	10
2.2	Pre-installation Precautions	10
2.3	CPU Installation	11
2.4	Installation of Heatsink and CPU fan	11
2.5	Installation of Memory Modules (DIMM)	12
2.6	Expansion Slots	12
2.7	Jumpers Setup	13
2.8	Connectors	14
3	BIOS Setup	16
3.1	BIOS Setup Utility	16
3.1.1	BIOS Menu Bar	16
3.1.2	Legend Bar	16
3.2	Main Menu	17
3.3	Advanced, Security, Power, Boot, and Exit Menus	19
4	Software Support	20
4.1	Installing Operating System	20
4.2	Support CD Information	20
4.2.1	Running Support CD	20
4.2.2	Drivers Menu	20
4.2.3	Utilities Menu	20
4.2.4	ASRock "PC-DIY Live Demo" Program	20
4.2.5	Contact Information	20
Appendix	21
1.	Advanced Menu	21
2.	Security Menu	25
3.	Power Menu	26
4.	Boot Menu	27
5.	Exit Menu	28

Chapter 1 Introduction

Thank you for purchasing ASRock GE Pro-HT / GE Pro-M2 motherboard, a reliable motherboard produced under ASRock's consistently stringent quality control. It delivers excellent performance with robust design conforming to ASRock's commitment to quality and endurance.

Chapter 1 and 2 of this manual contain introduction of the motherboard and step-by-step installation guide for new DIY system builders. Chapter 3 and 4 contain basic BIOS setup and Support CD information.

For advanced users' reference, the Appendix appearing on page 21 offers more advanced BIOS setup information.



Because the motherboard specifications and the BIOS software might be updated, the content of this manual will be subject to change without notice. In case any modifications of this manual occur, the updated version will be available on ASRock website without further notice. You may find the latest memory and CPU support lists on ASRock website as well.

ASRock website <http://www.asrock.com>

1.1 Package Contents

ASRock GE Pro-HT or GE Pro-M2 motherboard

(Micro ATX form factor: 9.6" x 7.5", 24.4 x 19.1 cm)

ASRock GE Pro-HT / GE Pro-M2 Quick Installation Guide

ASRock Intel-SiS Support CD

1 cable for IDE devices (1 x ATA 66 / 100 / 133)

1 cable for floppy drive (1 x ribbon cable)

1 ASRock I/O shield

1 COM port bracket

1 ASRock MR card (Optional)

1.2 Specifications

Platform:	Micro ATX form factor (9.6" x 7.5", 24.4 x 19.1 cm)
CPU:	Socket 478 for Intel® Pentium® 4/ Celeron® processor
Chipsets:	North Bridge (GE Pro-HT): SiS 651 chipset, FSB @ 533/400MHz, supports Hyper-Threading Technology (see CAUTION 1); North Bridge (GE Pro-M2): SiS 533/333 chipset, FSB @ 533/400MHz; South Bridge: SiS 962L chipset, supports USB 2.0, ATA 133
VGA:	SiS Real 256E, 4MB-64MB VRAM (share memory)
Memory:	2 DDR DIMM slots: DDR DIMM1 and DDR DIMM2 support PC1600 (DDR200) / PC2100 (DDR266) / PC2700 (DDR333), Max. 2GB;
IDE:	IDE1: ATA 133 / Ultra DMA Mode 6; IDE2: ATA 133 / Ultra DMA Mode 6; Can connect up to 4 IDE devices
Floppy Port:	Supports 2 floppy disk drives
Audio:	5.1 channels AC'97 Audio
LAN:	Speed: 802.3u (10/100 Ethernet), supports Wake-On-LAN
Hardware Monitor:	CPU temperature sensing (ASRock U-COP); Chassis temperature sensing; CPU overheat shutdown to protect CPU life (ASRock U-COP) (see CAUTION 2); Voltage monitoring: +12V, +5V, +3V, Vcore; CPU fan tachometer; Chassis fan tachometer
PCI slots:	2 slots with PCI Specification 2.2
AGP slot:	1 universal AGP slot, AGP 2.0 compliant, supports 3.3V / 1.5V, 4X / 2X / 1X AGP card
AMR slot:	1 slot, supports ASRock MR card (Optional)
USB 2.0:	4 default USB 2.0 ports and 1 extra set of header for 2 additional USB 2.0 ports upgrade (see CAUTION 3)
ASRock I/O™:	PS/2: 1 keyboard port / 1 mouse port; 1 RJ 45 port; 4 rear default USB 2.0 ports; 1 VGA port; 1 parallel port: ECP/EPP support; Audio Jack: Line Out/ Line In/ Microphone + Game port
BIOS:	AMI legal BIOS; Supports "Plug and Play"; ACPI 1.1 compliance wake up events; Supports jumperfree; SMBIOS 2.3.1 support; CPU frequency stepless control (only for advanced users' reference, see CAUTION 4)
OS:	Microsoft® Windows® 98SE / ME / 2000 / XP compliant

CAUTION!

1. About the setting of "Hyper Threading Technology", please check page 21.
2. While CPU overheat is detected, the system will automatically shutdown. Please check if the CPU fan on the motherboard functions properly before you resume the system. To improve heat dissipation, remember to spray thermal grease between the CPU and the heatsink when you install the PC system.
3. Power Management for USB 2.0 works fine under Microsoft® Windows® XP. It may not work properly under Microsoft® Windows® 98/ME/2000. Please refer to Microsoft® official document at <http://www.microsoft.com/whdc/hwdev/bus/USB/USB2support.msp>
4. Although GE Pro-HT / GE Pro-M2 offers stepless control, it is not recommended to perform over clocking. When the CPU frequency of GE Pro-HT / GE Pro-M2 is set to perform over clocking, other clocks, such as PCI clock, AGP clock and Memory clock will also be overclocked proportionally. Frequencies other than the recommended CPU bus frequencies may cause the instability of the system or damage the CPU and the motherboard.

1.3 Motherboard Layout (GE Pro-HT)

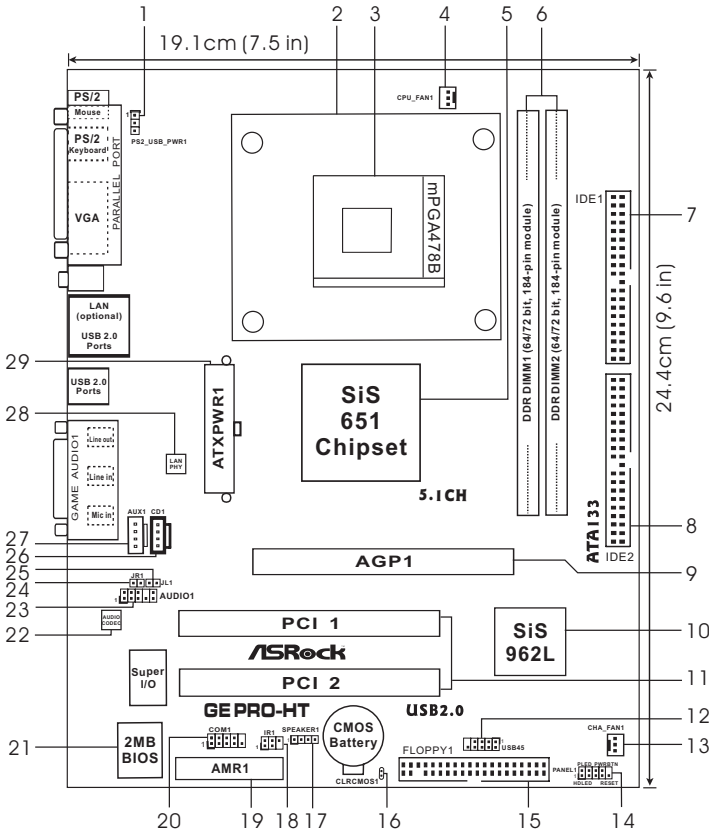

- | | | | |
|----|---------------------------------------|----|--|
| 1 | PS2_USB_PWR1 Jumper | 16 | Clear CMOS (CLRCMOS1, solder points) |
| 2 | CPU Heatsink Retention Module | 17 | External Speaker Connector (SPEAKER1) |
| 3 | CPU Socket | 18 | Infrared Module Connector (IR1) |
| 4 | CPU Fan Connector (CPU_FAN1) | 19 | AMR Slot (AMR1) |
| 5 | North Bridge Controller | 20 | Serial Port Connector (COM1) |
| 6 | 184-pin DDR DIMM Slots (DDR DIMM1-2) | 21 | Flash Memory |
| 7 | Primary IDE Connector (IDE1, Blue) | 22 | AUDIO CODEC |
| 8 | Secondary IDE Connector (IDE2, Black) | 23 | Front Panel Audio Connector (AUDIO1) |
| 9 | Accelerated Graphics Port (AGP1) | 24 | JR1 Jumper |
| 10 | South Bridge Controller | 25 | JL1 Jumper |
| 11 | PCI Slots (PCI 1-2) | 26 | Internal Audio Connector: CD1 (Black) |
| 12 | USB 2.0 Header (USB45, Blue) | 27 | Internal Audio Connector: AUX1 (White) |
| 13 | Chassis Fan Connector (CHA_FAN1) | 28 | LAN PHY |
| 14 | System Panel Connector (PANEL1) | 29 | ATX Power Connector (ATXPWR1) |
| 15 | Floppy Connector (FLOPPY1) | | |

1.4 Motherboard Layout (GE Pro-M2)

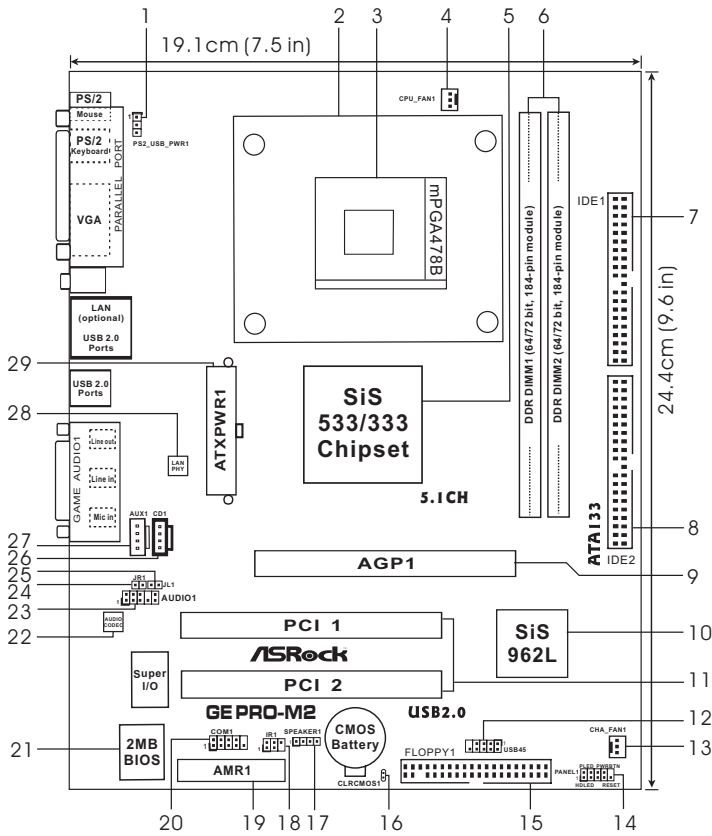

- | | | | |
|----|---------------------------------------|----|--|
| 1 | PS2_USB_PWR1 Jumper | 16 | Clear CMOS (CLRCMOS1, solder points) |
| 2 | CPU Heatsink Retention Module | 17 | External Speaker Connector (SPEAKER1) |
| 3 | CPU Socket | 18 | Infrared Module Connector (IR1) |
| 4 | CPU Fan Connector (CPU_FAN1) | 19 | AMR Slot (AMR1) |
| 5 | North Bridge Controller | 20 | Serial Port Connector (COM1) |
| 6 | 184-pin DDR DIMM Slots (DDR DIMM1-2) | 21 | Flash Memory |
| 7 | Primary IDE Connector (IDE1, Blue) | 22 | AUDIO CODEC |
| 8 | Secondary IDE Connector (IDE2, Black) | 23 | Front Panel Audio Connector (AUDIO1) |
| 9 | Accelerated Graphics Port (AGP1) | 24 | JR1 Jumper |
| 10 | South Bridge Controller | 25 | JL1 Jumper |
| 11 | PCI Slots (PCI 1-2) | 26 | Internal Audio Connector: CD1 (Black) |
| 12 | USB 2.0 Header (USB45, Blue) | 27 | Internal Audio Connector: AUX1 (White) |
| 13 | Chassis Fan Connector (CHA_FAN1) | 28 | LAN PHY |
| 14 | System Panel Connector (PANEL1) | 29 | ATX Power Connector (ATXPWR1) |
| 15 | Floppy Connector (FLOPPY1) | | |

1.5 ASRock I/O™ (GE Pro-HT / GE Pro-M2)

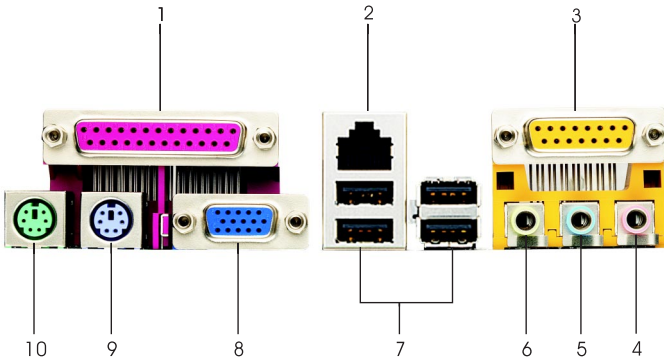

- | | | | |
|---|----------------------|----|-----------------------------|
| 1 | Parallel Port | 6 | Line Out (Lime) |
| 2 | RJ-45 Port | 7 | USB 2.0 Ports |
| 3 | Game Port | 8 | VGA Port |
| 4 | Microphone (Pink) | 9 | PS/2 Keyboard Port (Purple) |
| 5 | Line In (Light Blue) | 10 | PS/2 Mouse Port (Green) |

Chapter 2 Installation

GE Pro-HT / GE Pro-M2 is a Micro ATX form factor (9.6" x 7.5", 24.4 x 19.1 cm) motherboard. Before you install the motherboard, study the configuration of your chassis to ensure that the motherboard fits into it.



Make sure to unplug the power cord before installing or removing the motherboard. Failure to do so may cause physical injuries to you and damages to motherboard components.

2.1 Screw Holes

Place screws into the holes indicated by circles to secure the motherboard to the chassis.



Do not over-tighten the screws! Doing so may damage the motherboard.

2.2 Pre-installation Precautions

Take note of the following precautions before you install motherboard components or change any motherboard settings.

1. Unplug the power cord from the wall socket before touching any component.
2. To avoid damaging the motherboard components due to static electricity, NEVER place your motherboard directly on the carpet or the like. Also remember to use a grounded wrist strap or touch a safety grounded object before you handle components.
3. Hold components by the edges and do not touch the ICs.
4. Whenever you uninstall any component, place it on a grounded antistatic pad or in the bag that comes with the component.

Before you install or remove any component, ensure that the power is switched off or the power cord is detached from the power supply. Failure to do so may cause severe damage to the motherboard, peripherals, and/or components.

2.3 CPU Installation

- Step 1. Unlock the socket by lifting the lever up to a 90° angle.
- Step 2. Position the CPU directly above the socket such that its marked corner matches the base of the socket lever.
- Step 3. Carefully insert the CPU into the socket until it fits in place.



The CPU fits only in one correct orientation. DO NOT force the CPU into the socket to avoid bending of the pins.

- Step 4. When the CPU is in place, press it firmly on the socket while you push down the socket lever to secure the CPU. The lever clicks on the side tab to indicate that it is locked.

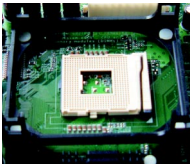

Step 1



Step 2, 3



Step 4

2.4 Installation of CPU Fan and Heatsink

Intel® Pentium® 4 CPU requires larger heatsink and cooling fan. Thermal grease between the CPU and the heatsink is also needed to improve heat dissipation. Make sure that the CPU and the heatsink are securely fastened and in good contact with each other. For proper installation, please kindly refer to the instruction manuals of the CPU fan and heatsink vendors.

2.5 Installation of Memory Modules (DIMM)

GE Pro-HT / GE Pro-M2 motherboard provides two 184-pin DDR (Double Data Rate) DIMM slots.



Please make sure to disconnect power supply before adding or removing DIMMs or the system components.

- Step 1. Unlock a DIMM slot by pressing the retaining clips outward.
- Step 2. Align a DIMM on the slot such that the notch on the DIMM matches the break on the slot.
- Step 3. Firmly insert the DIMM into the slot until the retaining clip snap back in place and the DIMM is properly seated.

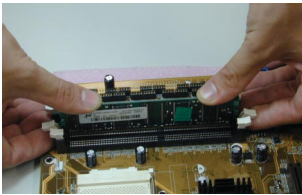

2.6 Expansion Slots (PCI, AMR, and AGP Slots)

There are 2 PCI slots, 1 AMR slot, and 1 AGP slot on GE Pro-HT or GE Pro-M2 motherboard.

PCI slots: The PCI slots are used to install expansion cards that have the 32-bit PCI interface.

AMR slot: The AMR slot is used to insert an ASRock MR card (optional) with v.92 Modem functionality.

AGP slot: The AGP slot is AGP 2.0 compliant and supports a 4X / 2X / 1X AGP card. The ASRock AGP slot has a special locking mechanism which can securely fasten the inserted graphics card.

Installing an expansion card

- Step 1. Before installing the expansion card, read the documentation of the expansion card and make necessary hardware settings for the card.
- Step 2. Remove the system unit cover (if your motherboard is already installed in a chassis).
- Step 3. Remove the bracket facing the slot that you intend to use. Keep the screws for later use.
- Step 4. Align the card connector with the slot and press firmly until the card is completely seated on the slot.
- Step 5. Fasten the card to the chassis with screws.
- Step 6. Replace the system cover.

2.7 Jumpers Setup

The illustration shows how jumpers are setup. When the jumper cap is placed on pins, the jumper is “SHORT”. If no jumper cap is placed on pins, the jumper is “OPEN”. The illustration shows a 3-pin jumper whose pin1 and pin2 are “SHORT” when jumper cap is placed on these 2 pins.

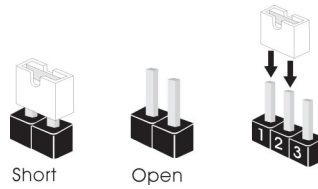

Jumper	Setting	Description
PS2_USB_PWR1 (see p.7/p.8 item 1)	 +5V +5VSB	Short pin2, pin3 to enable +5VSB (standby) for PS/2 or USB wake up events.

Note: To select +5VSB, it requires 2 Amp and higher standby current provided by power supply.

JR1 (see p.7/p.8 item 24)		
JL1 (see p.7/p.8 item 25)	fig. 1	fig. 2

- Note: When you connect speakers in back panel and front panel at the same time,
1. If the jumpers JL1 and JR1 are short (see fig. 1), both front panel and rear panel audio connectors can work.
 2. If both jumper caps on JL1 and JR1 are removed (see fig. 2), only front panel audio works.

However, it requires your front panel to support the function.

Clear CMOS

CLRCMOS1 (see p.7/p.8 item 16)	
	solder points



Note: CLRCMOS1 allows you to clear the data in CMOS. The data in CMOS includes system setup information such as system password, date, time, and system setup parameters. To clear and reset the system parameters to default setup, please turn off the computer and unplug the power cord, then short the solder points for more than 3 seconds by using metal material, e.g., a paper clip.

2.8 Connectors



Connectors are NOT jumpers. DO NOT place jumper caps over these connectors.

Connector	Figure	Description
-----------	--------	-------------

FDD connector (33-pin FLOPPY1) (see p.7/p.8 item 15)		
--	---	---

Note: Match the red marking on the floppy ribbon cable with Pin1.

Primary IDE connector (Blue)

(39-pin IDE1, see p.7/p.8 item 7)



Secondary IDE connector (Black)

(39-pin IDE2, see p.7/p.8 item 8)



Connect this BLUE end to the motherboard  Connect this BLACK end to the IDE devices

80-Pin ATA 100/133 cable

Note: To optimize compatibility and performance, please connect your hard disk drive to the primary IDE connector (IDE1, blue) and CD-ROM to the secondary IDE connector (IDE2, black).

USB 2.0 header

(9-pin USB45)

(see p.7/p.8 item 12)

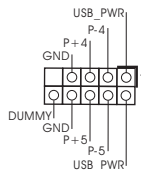

ASRock I/O™ provides 4 default USB 2.0 ports. If those USB 2.0 ports on the rear panel are not sufficient, this USB 2.0 header is available to support 2 additional USB 2.0 ports.

Infrared module connector

(5-pin IR1)

(see p.7/p.8 item 18)

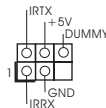

This connector supports an optional wireless transmitting and receiving infrared module.

Internal audio connectors

(4-pin CD1, 4-pin AUX1)

(CD1: see p.7/p.8 item 26)

(AUX1: see p.7/p.8 item 27)

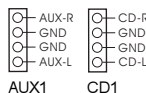

These connectors allow you to receive stereo audio input from sound sources such as a CD-ROM, DVD-ROM, TV tuner card, or MPEG card.

Front panel audio connector

(9-pin AUDIO1)

(see p.7/p.8 item 23)

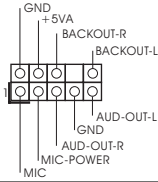

This is an interface for front panel audio cable that allows convenient connection and control of audio devices.

System panel connector

(9-pin PANEL1)

(see p.7/p.8 item 14)

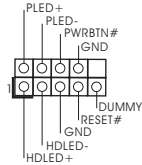

This connector accommodates several system front panel functions.

External speaker connector

(4-pin SPEAKER1)

(see p.7/p.8 item 17)

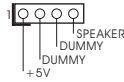

This connector allows you to attach to an external speaker.

Chassis fan connector

(3-pin CHA_FAN1)

(see p.7/p.8 item 13)

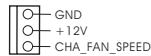

Connect the fan cable to the connector matching the black wire to the ground pin.

CPU fan connector

(3-pin CPU_FAN1)

(see p.7/p.8 item 4)

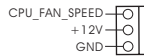

Connect the fan cable to the connector matching the black wire to the ground pin.

ATX power connector

(20-pin ATXPWR1)

(see p.7/p.8 item 29)



Connect an ATX power supply to the connector.

Serial port connector

(9-pin COM1)

(see p.7/p.8 item 20)

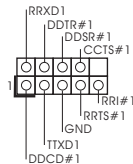

This COM1 header supports a serial port module.

Chapter 3 BIOS Setup

3.1 BIOS Setup Utility

This section explains how to configure your system using the BIOS Setup Utility. The Flash Memory on the motherboard stores the BIOS Setup Utility. When you start up the computer, there is a chance for you to run the BIOS Setup. Press <F2> during the Power-On-Self-Test (POST) to enter the BIOS Setup Utility, otherwise, POST continues with its test routines.

If you wish to enter the BIOS Setup after POST, restart the system by pressing <Ctl> + <Alt> + <Delete>, or by pressing the reset button on the system chassis. You can also restart by turning the system off and then back on.

The BIOS Setup Utility is designed to be user-friendly. It is a menu-driven program, which allows you to scroll through its various sub-menus and select among the predetermined choices.



Because the BIOS software is constantly being updated, the following BIOS setup screens and descriptions are for reference purpose only, and may not exactly match what you see on your screen.

3.1.1 BIOS Menu Bar

The top of the screen has a menu bar with the following selections:

MAIN	Sets up the basic system configuration
ADVANCED	Sets up the advanced features
SECURITY	Sets up the security features
POWER	Configures Power Management features
BOOT	Configures the default system device that is used to locate and load the Operating System
EXIT	Exits the current menu or the BIOS Setup

To access the menu bar items, press the right or left arrow key on the keyboard until the desired item is highlighted.

3.1.2 Legend Bar

At the bottom of the Setup Screen is a legend bar. The following table lists the keys in the legend bar with their corresponding functions.

Navigation Key(s)	Function Description
<F1>	Displays the General Help Screen
<ESC>	Jumps to the Exit menu or returns to the upper menu from the current menu
↑ / ↓	Moves cursor up or down between fields
← / →	Selects menu to the left or right
+ / -	Increases or decreases values
<Enter>	Brings up a selected menu for a highlighted field
<F9>	Loads all the setup items to default value
<F10>	Saves changes and exits Setup

3.2 Main Menu

When you enter the BIOS Setup Utility, the following screen appears.

AMIBIOS SETUP UTILITY - VERSION 3.31a			
Main	Advanced	Security	Power Boot Exit
System Date		Jul 17 2003 Thu	[Setup Help]
System Time		20:07:40	Month: Jan - Dec
▶ Floppy Drives			Day: 01 - 31
▶ IDE Devices			Year: 1980 - 2099
BIOS Version	GE PRO-HT BIOS P1.00		
Processor Type	Pentium (R) 4 CPU		
Processor Speed	2100 MHz		
Cache Size	512 KB		
Microcode Update	F23 / 08		
Total Memory	224 MB + 32 MB Share Memory		
DDR1	256 MB / 333 MHz		
DDR2	None		
F1:Help	F11:Select Item	+/-:Change Values	F9:Setup Defaults
Esc:Exit	→:Select Menu	Enter:Select	F10:Save & Exit
		▶Sub-Menu	

System Date [Month/Day/Year]

Set the system date that you specify. Valid values for month, day, and year are Month: (Jan to Dec), Day: (1 to 31), Year: (up to 2099). Use ↑ ↓ keys to move between the Month, Day and Year fields.

System Time [Hour:Minute:Second]

Set the system to the time that you specify. Use ↑ ↓ keys to move between the Hour, Minute and Second fields.

Floppy Drives

Use this to set the type of floppy drives installed.

IDE Devices

Use this to configure IDE devices.

TYPE

To set the type of the IDE device, first, please select "IDE Devices" on Main menu and press <Enter> to get into the sub-menu. Then, select among "Primary IDE Master", "Primary IDE Slave", "Secondary IDE Master", and "Secondary IDE Slave" to make configuration of its type. Below are the configuration options.

AMIBIOS SETUP UTILITY - VERSION 3.31a	
Main	
Primary IDE Master:	[Setup Help]
Type	Auto
Cylinders	
Heads	
Write Precompensation	
Sectors	
Maximum Capacity	
LBA Mode	On
Block Mode	On
Fast Programmed I/O Modes	Auto
32 Bit Transfer Mode	On
Ultra DMA Mode	Auto
Select how to set the parameters of drive, Or Select [AUTO] to set all HDD parameters automatically.	
F1:Help	F10:Save & Exit
Esc:Previous Menu	Enter:Select
↑:Select Item	→:Sub-Menu
+/-:Change Values	

[USER]: It allows user to manually enter the number of cylinders, heads, and sectors per track for the drive.



Before attempting to configure a hard disk drive, make sure you have the correct configuration information supplied by the drive manufacturer. Incorrect settings may cause the system to fail to recognize the installed hard disk.

[Auto]: Select [Auto] to automatically detect hard disk drive. If auto-detection is successful, the BIOS Setup automatically fills in the correct values for the remaining fields on this sub-menu. If the auto-detection fails, it may be due to that the hard disk is too old or too new. If the hard disk was already formatted on an older system, the BIOS Setup may detect incorrect parameters. In these cases, select [User] to manually enter the IDE hard disk drive parameters.



After entering the hard disk information into BIOS, use a disk utility, such as FDISK, to partition and format new IDE hard disk drives. This is necessary so that you can write or read data from the hard disk. Make sure to set the partition of the Primary IDE hard disk drives to active.

[CD/DVD]: This is used for IDE CD/DVD drives.

[ARMD]: This is used for IDE ARMD (ATAPI Removable Media Device), such as MO.

Cylinders

This is used to configure the number of cylinders. Refer to the drive documentation to determine the correct value.

Heads

This is used to configure the number of read/write heads. Refer to the drive documentation to determine the correct values.

Write Pre-compensation

Enter Write Pre-compensation sector. Refer to the drive documentation to determine the correct value.

Sectors

This is used to configure the number of sectors per track. Refer to the drive documentation to determine the correct value.

Maximum Capacity

This field shows the drive's maximum capacity as calculated by the BIOS based on the drive information you entered.

LBA Mode

This allows user to select the LBA mode for a hard disk > 512 MB under DOS and Windows; for Netware and UNIX user, select [Off] to disable the LBA mode.

Block Mode

Set the block mode to [On] will enhance hard disk performance by reading or writing more data during each transfer.

Fast Programmed I/O Modes

This allows user to set the PIO mode to enhance hard disk performance by optimizing the hard disk timing.

32 Bit Transfer Mode

It allows user to enable 32-bit access to maximize the IDE hard disk data transfer rate.

Ultra DMA Mode

Ultra DMA capability allows improved transfer speeds and data integrity for compatible IDE devices. Set to [Disabled] to suppress Ultra DMA capability.

3.3 Advanced, Security, Power, Boot, and Exit Menus

Detailed descriptions of these menus are listed in the Appendix. See page 21.

Chapter 4 Software Support

4.1 Install Operating System

This motherboard supports various Microsoft® Windows® operating systems: 98 SE / ME / 2000 / XP. Because motherboard settings and hardware options vary, use the setup procedures in this chapter for general reference only. Refer to your OS documentation for more information.

4.2 Support CD Information

The Support CD that came with the motherboard contains necessary drivers and useful utilities that enhance the motherboard features.

4.2.1 Running The Support CD

To begin using the support CD, insert the CD into your CD-ROM drive. The CD automatically displays the Main Menu if "AUTORUN" is enabled in your computer. If the Main Menu did not appear automatically, locate and double click on the file "ASSETUP.EXE" from the BIN folder in the Support CD to display the menus.

4.2.2 Drivers Menu

The Drivers Menu shows the available devices drivers if the system detects installed devices. Please install the necessary drivers to activate the devices.

4.2.3 Utilities Menu

The Utilities Menu shows the applications software that the motherboard supports. Click on a specific item then follow the installation wizard to install it.

4.2.4 ASRock PC-DIY Live Demo Program

ASRock presents you a multimedia PC-DIY live demo, which shows you how to install your own PC system step by step. You can find the file through the following path:

```
..\MPEGAV\AVSEQ01.DAT
```

To see this demo program, you can run Microsoft® Media Player® to play the file.

4.2.5 Contact Information

If you need to contact ASRock or want to know more about ASRock, welcome to visit ASRock's website at <http://www.asrock.com>; or you may contact your dealer for further information.

Appendix: Advanced BIOS Setup

This section will introduce you the following BIOS Setup menus: “Advanced,” “Security,” “Power,” “Boot,” and “Exit.”

1. Advanced BIOS Setup Menu

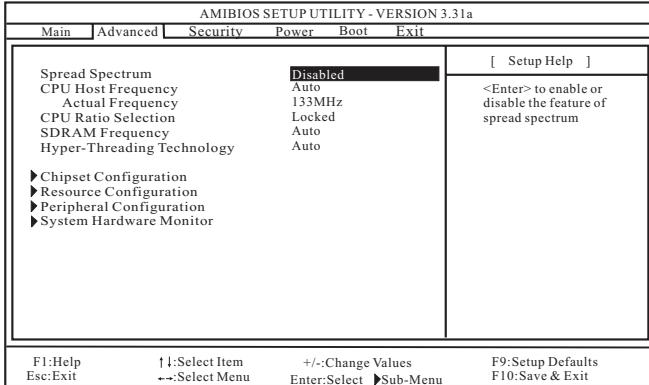

Spread Spectrum:

This field should always be [Disabled] for better system stability.

CPU Host Frequency:

This shows current CPU host frequency of the installed motherboard.

CPU Ratio Selection:

CPU Ratio is the multiple that times the front side bus frequency will equal the core speed of the installed processor. Whether the option is open or locked is determined by the installed processor.

SDRAM Frequency:

If [Auto] is selected, the motherboard will detect the memory module(s) inserted and assigns appropriate frequency automatically.

Hyper-Threading Technology (for GE Pro-HT only):

To enable this feature, it requires a computer system with an Intel® Pentium®4 processor that supports Hyper-Threading technology and an operating system that includes optimization for this technology, such as Microsoft® Windows® XP. Set to [Auto] if using Microsoft® Windows® XP, or Linux kernel version 2.4.18 or higher. This option will be hidden if the current CPU does not support Hyper-Threading technology.

Chipset Configuration:

AMIBIOS SETUP UTILITY - VERSION 3.31a		
Advanced		
Chipset Configuration		[Setup Help]
AGP Aperture Size	64MB	<Enter> to select the size of mapped memory for graphics data.
Onboard VGA Share Memory	32MB	
USB Controller	Enabled	
USB Device Legacy Support	Disabled	
DRAM CAS# Latency	Auto	
F1:Help ↑:Select Item +/-:Change Values F9:Setup Defaults Esc:Previous Menu Enter:Select ▶:Sub-Menu F10:Save & Exit		

AGP Aperture Size: It refers to a section of the PCI memory address range used for graphics memory. It is recommended to leave this field at the default value unless your AGP card requires other sizes.

OnBoard VGA Share Memory: This allows you to select the size of share memory for onboard VGA. Onboard VGA will get better resolution if larger size of share memory is selected. Please do not select [Disabled] if PCI graphics card is not inserted.

USB Controller: Use this to enable or disable the use of USB controller.

USB Device Legacy Support: Use this to enable or disable support to emulate legacy I/O devices such as mouse, keyboard,... etc.

DRAM CAS# Latency:

This parameter controls the latency between the read command and the time the data available.

Resource Configuration:

AMIBIOS SETUP UTILITY - VERSION 3.31a			
Advanced			
Resource Configuration		[Setup Help]	
PCI Latency Timer (PCI Clocks)	32	<Enter> to select PCI clocks. Leave on default setting for the best PCI performance.	
Primary Graphics Adapter	PCI		
F1:Help	F4:Select Item	+/-:Change Values	F9:Setup Defaults
Esc:Previous Menu		Enter:Select	F10:Save & Exit
		▶Sub-Menu	

PCI Latency Timer (PCI Clocks): The default is 32. We recommend you to keep the default value unless your PCI expansion cards' specifications require other settings.

Primary Graphics Adapter: This allows you to select [PCI], [Add-on AGP], or [OnBoard VGA] as the primary graphics adapter.

Peripheral Configuration:

AMIBIOS SETUP UTILITY - VERSION 3.31a			
Advanced			
Peripheral Configuration		[Setup Help]	
OnBoard FDC	Auto	<Enter> to enable or disable the floppy drive controller.	
OnBoard Serial Port	Auto		
OnBoard Infrared Port	Disabled		
OnBoard Parallel Port	Auto		
Parallel Port Mode	ECP+EPP		
EPP Version	EPP 1.9		
Parallel Port IRQ	Auto		
Parallel Port DMA Channel	N/A		
OnBoard Midi Port	Disabled		
Midi IRQ Select	5		
OnBoard Game Port	200h		
OnBoard IDE	Both		
OnBoard LAN	Enabled		
OnBoard AC'97 Audio	Auto		
OnBoard MC'97 Modem	Auto		
F1:Help	F4:Select Item	+/-:Change Values	F9:Setup Defaults
Esc:Previous Menu		Enter:Select	F10:Save & Exit
		▶Sub-Menu	

OnBoard FDC: Use this to enable or disable floppy drive controller.

OnBoard Serial Port: Use this to set addresses for the onboard serial ports or disable serial ports. Configuration options: [Auto], [Disabled], [3F8 / IRQ4 / COM1], [2F8 / IRQ3 / COM2], [3E8 / IRQ4 / COM3], [2E8 / IRQ3 / COM4].

OnBoard Infrared Port: You may select [Auto] or [Disabled] for this onboard infrared port feature.

OnBoard Parallel Port: Select Parallel Port address or disable Parallel Port.

Configuration options: [Auto], [Disabled], [378], [278].

Parallel Port Mode: Set the operation mode of the parallel port. The default value is [ECP+EPP]. If this option is set to [ECP+EPP], it will show the EPP version in the following item, "EPP Version".

OnBoard Midi Port: Select address for Midi Port or disable Midi Port.

Configuration options: [Disabled], [330], [300], [310], [320].

Midi IRQ Select: Use this to select Midi IRQ. Configuration options: [3], [4], [5], [7], [10], [11].

OnBoard Game Port: Select address for Game Port or disable Game Port.

Configuration options: [Disabled], [200h], [208h], .

OnBoard IDE: You may enable either the primary IDE channel or the secondary IDE channel. Or you may enable both the primary and the secondary IDE channels by selecting [Both]. Set to [Disabled] will disable the both.

Configuration options: [Disabled], [Primary], [Secondary], [Both].

OnBoard LAN: This allows you to enable or disable the "OnBoard LAN" feature.

OnBoard AC'97 Audio: Select [Disabled], [Auto] or [Enabled] for the onboard AC'97 Audio feature.

OnBoard MC'97 Modem: Select [Auto] or [Disabled] for the onboard MC'97 Modem feature.

System Hardware Monitor: You can check the status of the hardware on your system. It allows you to monitor the parameters for CPU temperature, Motherboard temperature, CPU fan speed, and critical voltage.

AMIBIOS SETUP UTILITY - VERSION 3.31a	
Advanced	
System Hardware Monitor	[Setup Help]
CPU Temperature	35°C / 95°F
M/B Temperature	27°C / 82°F
CPU Fan Speed	3110 RPM
Chassis Fan Speed	0 RPM
Vcore	1.728 V
+ 3.30V	3.312 V
+ 5.00V	4.975 V
+12.00V	12.167 V

F1:Help ↑:Select Item +/-:Change Values F9:Setup Defaults
Esc:Previous Menu Enter:Select ▶Sub-Menu F10:Save & Exit

2. Security Setup Menu

AMIBIOS SETUP UTILITY - VERSION 3.31a			
Main	Advanced	Security	Power Boot Exit
Supervisor Password	Clear		[Setup Help]
User Password	Clear		<Enter> to set the supervisor password.
Set Supervisor Password	[Enter]		
Set User Password	[Enter]		
Password Check	Setup		
F1:Help Esc:Exit	↑↓:Select Item ←→:Select Menu	+/-:Change Values Enter:Select	F9:Setup Defaults F10:Save & Exit

Supervisor Password: This field shows the status of the Supervisor Password.

[Clear]: No password has been set.

[Set]: Supervisor password has been set.

User Password: This field shows the status of the User Password.

[Clear]: No password has been set.

[Set]: User password has been set.

Set Supervisor Password: Press <Enter> to set Supervisor Password. Valid password can be a 1 to 6 alphanumeric characters combination. If you already have a password, you must enter your current password first in order to create a new password.

Set User Password: Press <Enter> to set User Password. Valid password can be a 1 to 6 alphanumeric characters combination. If you already have a password, you must enter your current password first in order to create a new password.

Password Check: Select the check point for "Password Check". Configuration options: [Setup], [Always]. If [Setup] option is selected, the "Password Check" is performed before BIOS setup. If [Always] option is selected, the "Password Check" is performed before both boot-up and BIOS setup.

3. Power Setup Menu

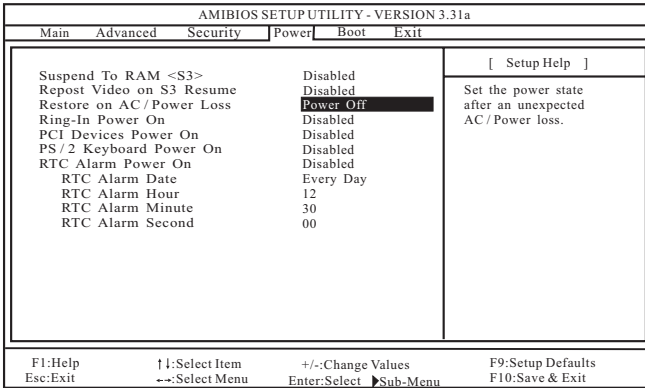

Suspend to RAM (S3): This field allows you to select whether to auto-detect or disable the ACPI Suspend-to-RAM feature. Select [Auto] will enable this feature if the system supports it.

Repost Video on S3 Resume: This feature allows you to repost video on S3 resume. It is recommended to enable this feature under Microsoft® Windows® 98 / ME.

Restore on AC/Power Loss: This allows you to set the power state after an unexpected AC/Power loss. If [Power Off] is selected, the AC/Power remains off when the power recovers. If [Power On] is selected, the AC/Power resumes and the system starts to boot up when the power recovers.

Ring-in Power On: Use this to enable or disable Ring-in signals to turn on the system from the power-soft-off mode.

PCI Devices Power On: Use this to enable or disable PCI devices to turn on the system from the power-soft-off mode.

PS/2 Keyboard Power On: Use this to enable or disable PS/2 keyboard to turn on the system from the power-soft-off mode.

RTC Alarm Power On: Use this to enable or disable RTC (Real Time Clock) to power on the system. If [Enable] is selected, you must fill the RTC Alarm Date / Hour / Minute / Second sub-fields with the actual wake up time you desire.

4. Boot Setup Menu

AMIBIOS SETUP UTILITY - VERSION 3.31a						
Main	Advanced	Security	Power	Boot	Exit	
Quick Boot Mode	Enabled	[Setup Help]				
Boot Up Num-Lock	On	<Enter> to enable or disable the quick boot mode.				
Boot To OS/2	No					
▶ Boot Device Priority						
F1:Help Esc:Exit	↑↓:Select Item ←→:Select Menu	+/-:Change Values Enter:Select	▶Sub-Menu			F9:Setup Defaults F10:Save & Exit

Quick Boot Mode: Enable this mode will speed up the boot-up routine by skipping memory retestings.

Boot Up Num-Lock: If this is enabled, it will automatically activate the Numeric Lock function after boot-up.

Boot To OS/2: Select [Yes] will enable boot-up to OS/2 operating system.

Boot Device Priority: This allows you to set the boot device priority.

5. Exit Menu

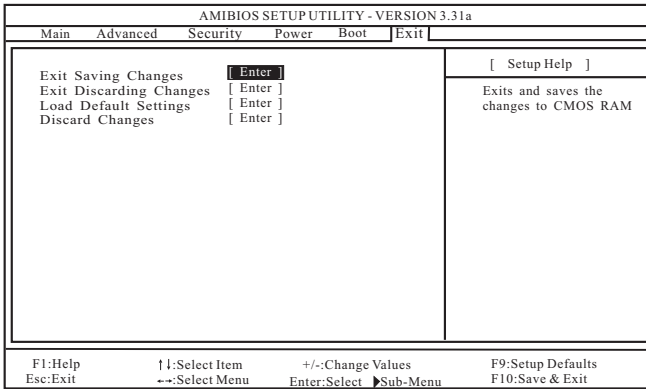

Exit Saving Changes: After you enter the sub-menu, the message “Save current settings and exit” will appear. If you press <ENTER>, it will save the current settings and exit the BIOS SETUP Utility.

Exit Discarding Changes: After you enter the submenu, the message “Quit without saving changes” will appear. If you press <ENTER>, you will exit the BIOS SETUP Utility without making any changes to the settings.

Load Default Settings: After you enter the submenu, the message “Load default settings” will appear. If you press <Enter>, it will load the default values for all the setup configuration.

Discard Changes: After you enter the sub-menu, the message “Load setup original values” will appear. If you press <ENTER>, original values will be restored and all changes are discarded.